

Jul.1.2019 Copyright 2019 HIROSE ELECTRIC CO., LTD. All Rights Reserved.  
In case of consideration for using Automotive equipment / device which demand high reliability, kindly contact our sales window correspondents.

△ Wholly-revised

Position and thickness of contact point after assembly of FFC

Thickness of contact point :  $0.96 \pm 0.05$

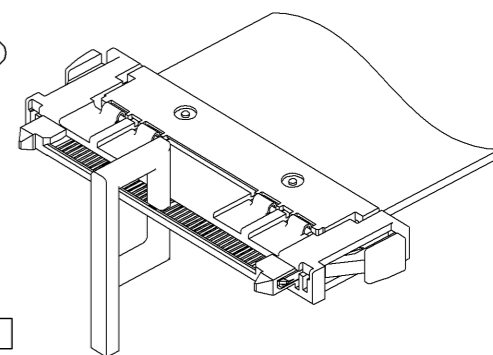
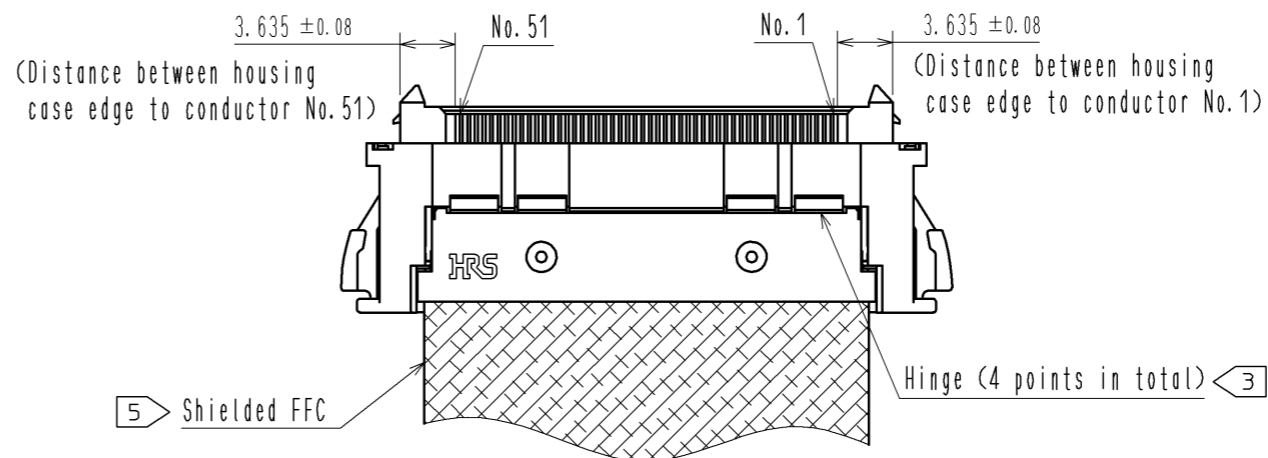

Measurement example : Micrometer

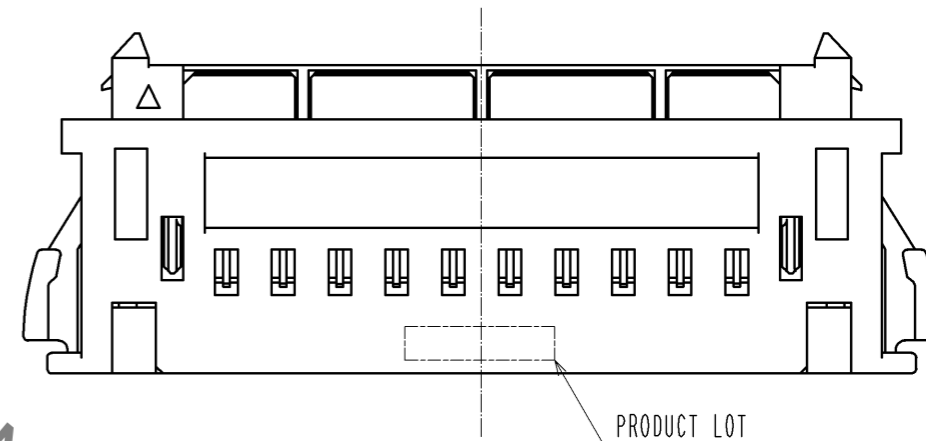
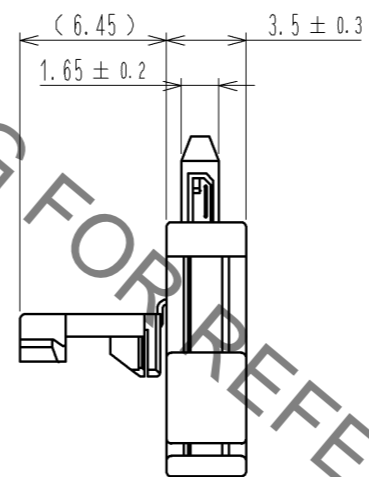
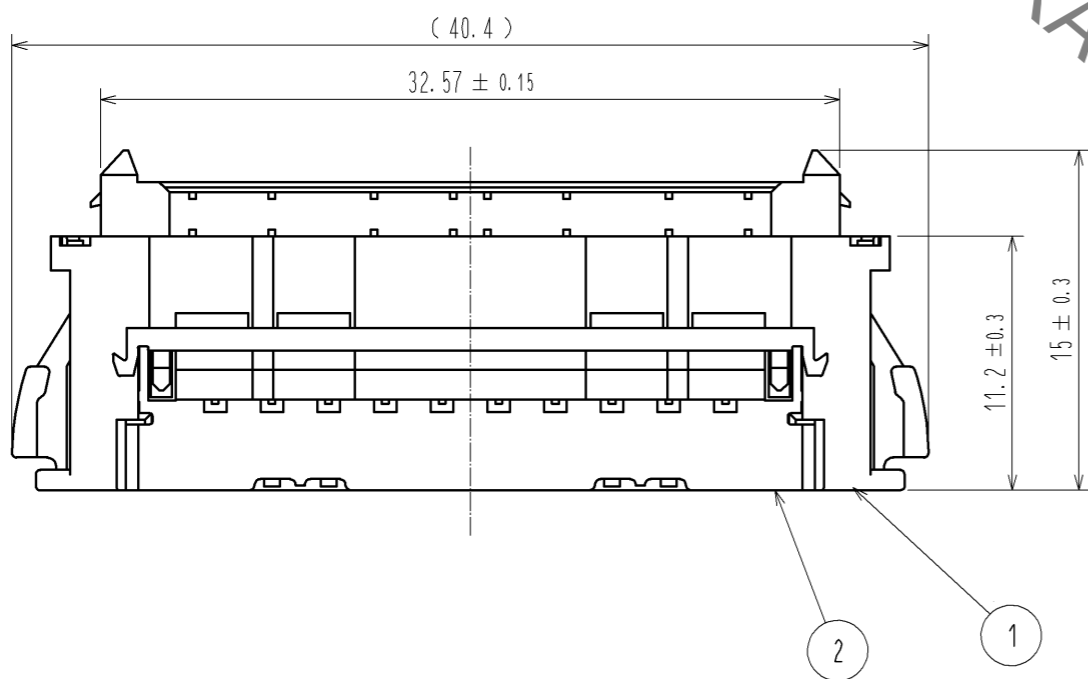

- NOTE
- 1 ( ) indicates a reference dimension.
  - 2 Manufacturing process could cause scratch and/or punch mark on the product, and/or shrinkage on the plastic resin without affecting the product performance.
  - 3 Crack or fracture on hinge connection generated during cable assembly is acceptable, provided that it is only 1 of 4 points, which does not influence the connection performance.
  - 4 The connectors are delivered in tray packaging.
  - 5 The applicable cable of the connector is a FFC manufactured according to our specifications. Impedance matched shielded FFC is recommended in order to keep Signal-integrity performance.
  - 6 Basically, performance is not guaranteed when mated to receptacles manufactured by other companies.

2	PHOSPHOR BRONZE	OVER PLATING:TIN PLATING 1μm min. UNDER PLATING:NICKEL 0.2μm min.			
1	PBT	BLACK UL94V-0	3	PS	(TRAY)
NO.	MATERIAL	FINISH . REMARKS	NO.	MATERIAL	FINISH . REMARKS
UNITS mm		SCALE FREE	COUNT 6	DESCRIPTION OF REVISIONS DIS-F-005314	DESIGNED KN. SHIBUYA
<b>HRS</b> HIROSE ELECTRIC CO., LTD.		APPROVED : HS. OKAWA	10. 01. 16	DRAWING NO. EDC3-327150-00	CHECKED HT. YAMAGUCHI
		CHECKED : HT. YAMAGUCHI	10. 01. 15	PART NO. FX16M2-51P-HC	DATE 11. 02. 23
		DESIGNED : AH. EDASHIGE	10. 01. 15	CODE NO. CL575-3263-0-00	
		DRAWN : AH. EDASHIGE	10. 01. 15		

Jul.1.2019 Copyright 2019 HIROSE ELECTRIC CO., LTD. All Rights Reserved.  
In case of consideration for using Automotive equipment / device which demand high reliability, kindly contact our sales window correspondents.

DRAWING FOR PACKING (1:2)

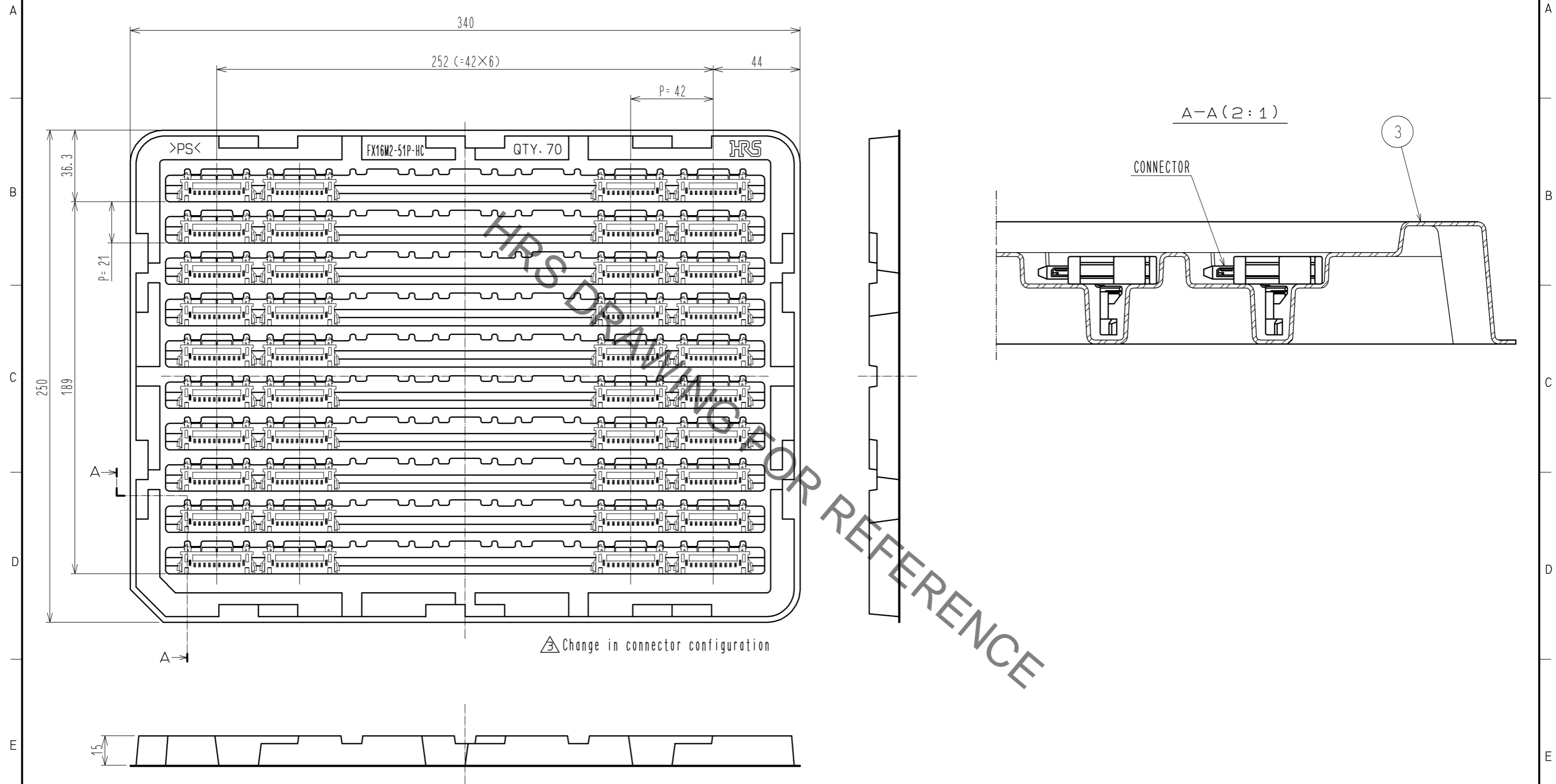

△ Change in connector configuration

- 注 1 One tray contains 70 connectors.
- 注 2 The dimensions are for reference.

<b>HRS</b>	DRAWING NO.	EDC3-327150-00	
	PART NO.	FX16M2-51P-HC	
	CODE NO.	CL575-3263-0-00	
			2/6

Jul.1.2019 Copyright 2019 HIROSE ELECTRIC CO., LTD. All Rights Reserved.  
In case of consideration for using Automotive equipment / device which demand high reliability, kindly contact our sales window correspondents.

# HANDLING INSTRUCTIONS

Wholly-revised

## 【1】 Insertion to on-board connector

The connector mating is keyed. Align the marks as shown in the figure for mating. Insert the connector completely until they are locked at both ends.

RECEPTACLE : FX16M2-\*\*S-0.5SH

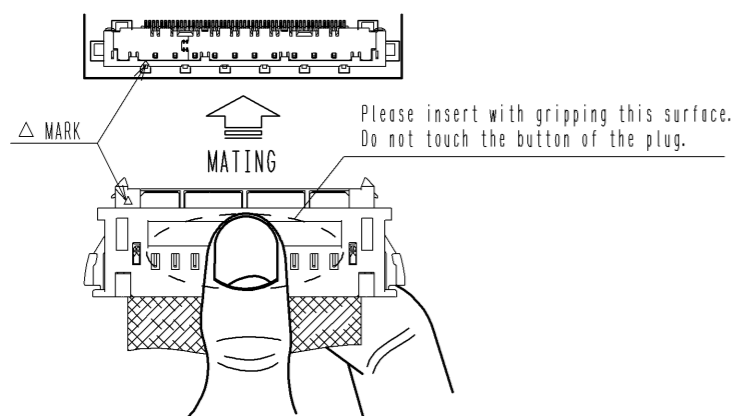

The connectors have a reverse-insertion prevention structure. However, the connectors may be damaged when inserted reversely with the force of 25N or more. Avoid a forceful insertion and make sure to confirm that the connectors are aligned with the marks before the mating operation.

Avoid angled insertion as described in the following 'Incorrect insertion', or the connector and/or FFC could be broken.

## 【2】 Withdrawal from on-board connector

The connectors are locked while they are mated. In order to unmate the connectors, pull out straight with the button pushed to release the lock. At this time, do not pull the FFC.

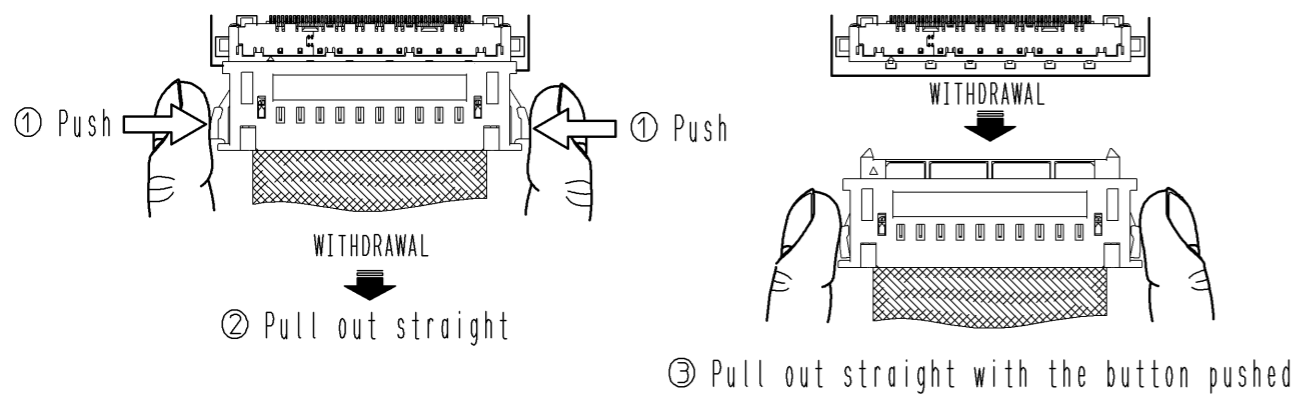

Also avoid the withdrawal in angle, which may damage the connectors.

## <Incorrect insertion>

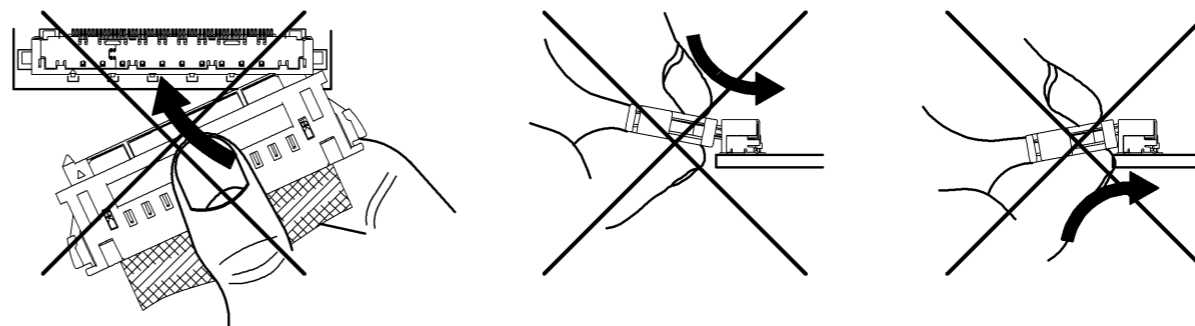

## <Incorrect withdrawal>

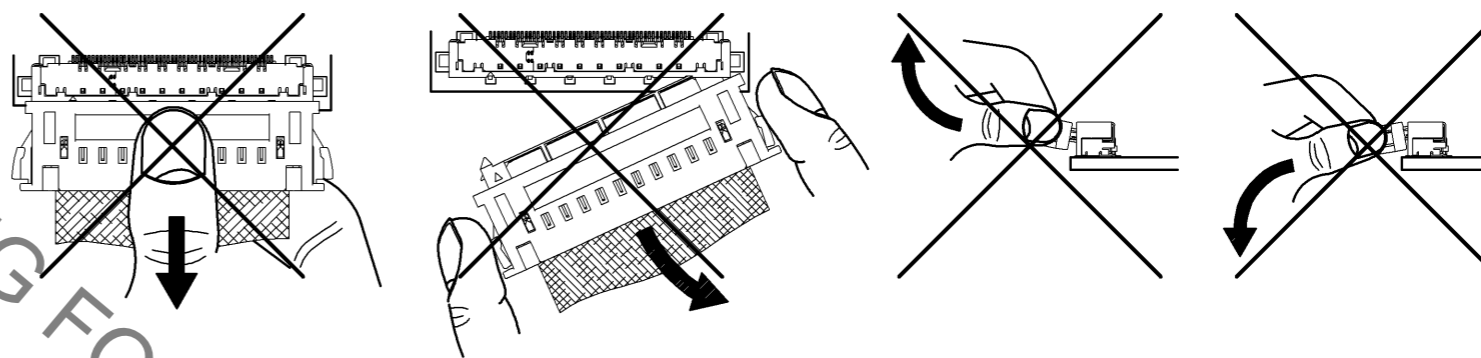

## 【3】 Correction of the position when pulling the plug without unlocking.

When the plug is pulled without unlocking operation, mate the plug again and then withdraw in correct manner.

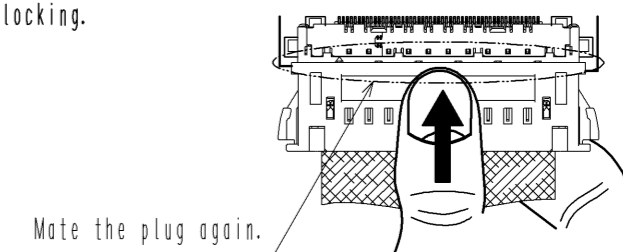

## 【4】 For the case that connector is withdrawn in condition that lock on one side is locked

In case connector is withdrawn in condition that lock on one side is locked, it could damage the locking part. In such case, do not withdraw forcefully, but mate the plug again and pull out the plug in condition that the two locks are locked and withdraw with <Correct withdrawal> method.

In case connector is withdrawn with lock that is locked on one side, mate the plug again and withdraw with <Correct withdrawal> method.

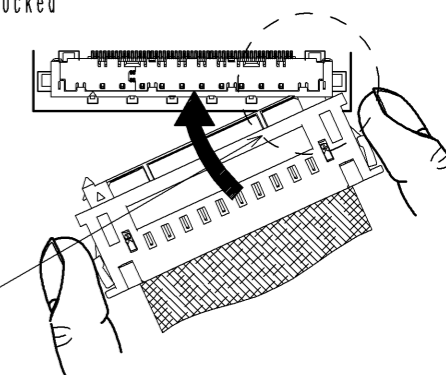

### \*NOTE:

The figures of the connector shown herein are described with a representative number of contacts just for operation instruction. Therefore, the appearance could differ from the actual connectors. Refer to the drawing for the actual design (sheet 1).

<b>HRS</b>	DRAWING NO.	EDC3-327150-00
	PART NO.	FX16M2-51P-HC
	CODE NO.	CL575-3263-0-00
		3/6

HRS DRAWING FOR REFERENCE

Jul.1.2019 Copyright 2019 HIROSE ELECTRIC CO., LTD. All Rights Reserved.  
In case of consideration for using Automotive equipment / device which demand high reliability, kindly contact our sales window correspondents.

Wholly-revised

**[5] After mating**

Carefully wire FFC, so that excessive force will not be applied to the mated connector.  
Pulling the FFC with the force of 10N or more may damage the connector.  
It may also cause FFC breakage. Take a caution to avoid pulling the FFC.

Repetitive FFC strokes could also cause FFC breakage as well.  
Do not use the connector under the environment of repetitive FFC strokes.

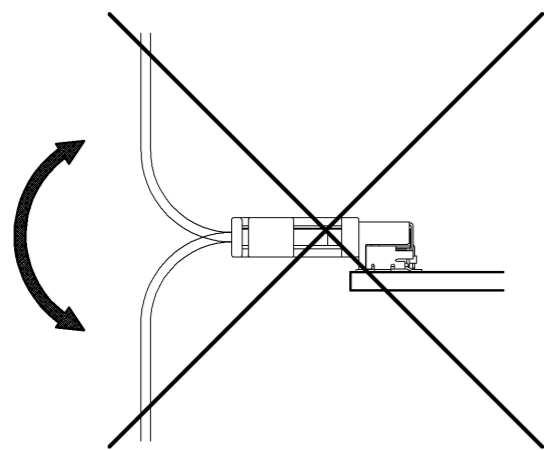

Repetitive FFC strokes

Take enough bend radius and/or distance from the connector for FFC not to apply stress to the connector base when the application requires FFC bend back.

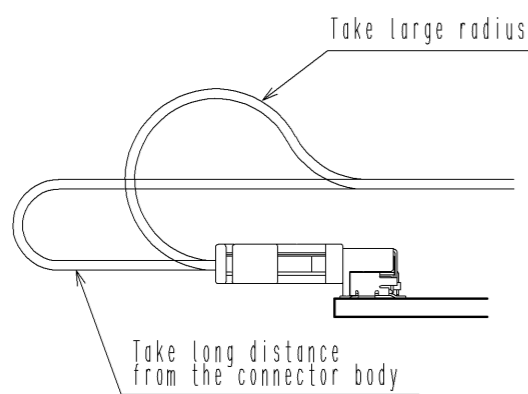

Application of FFC bend back

**PRECAUTIONS FOR HARNESS**

\*Please make sure not to touch conductor of FFC and metal lock.

**[1] How to insert FFC**

FFC needs to be inserted straight in alignment with mold lib as shown on illustration below.  
In case FFC is inserted wrong direction, FFC can not be inserted.  
In the worst case, FFC will be deformed, plastic housing, spring terminal will be broken, so please be aware of these points.

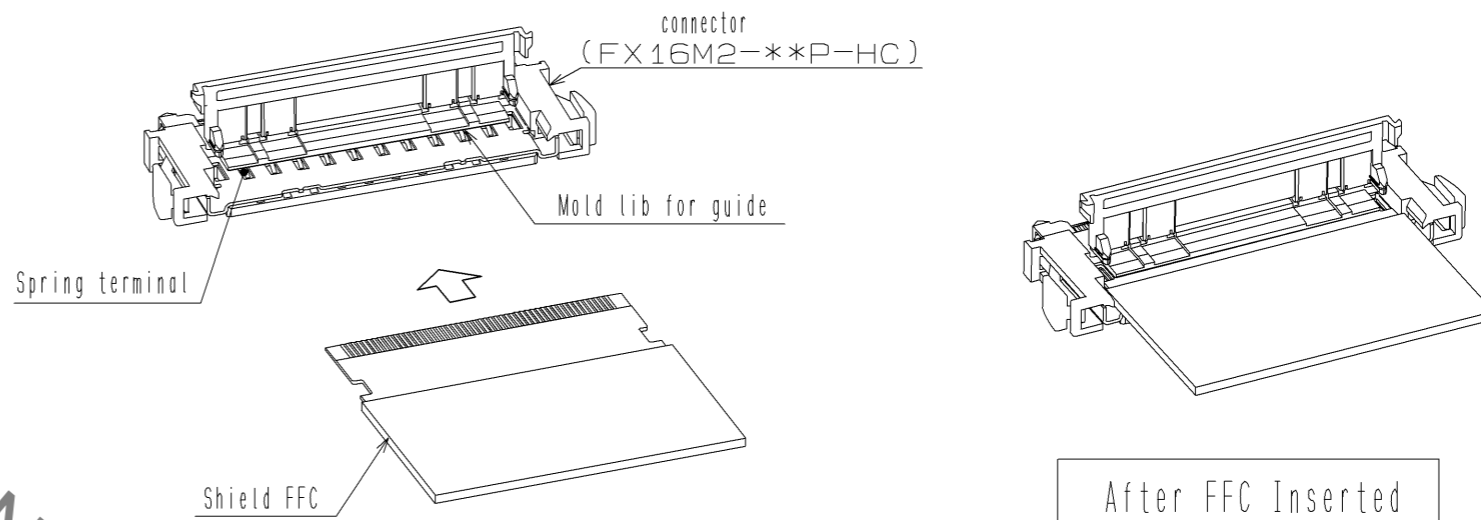

**[2] How to check FFC inserted position**

Verify that the position of FFC end face from directly above to check whether FFC inserted to correct position  
\*When FFC inserted correctly, FFC end face hits the wall of plastic housing.

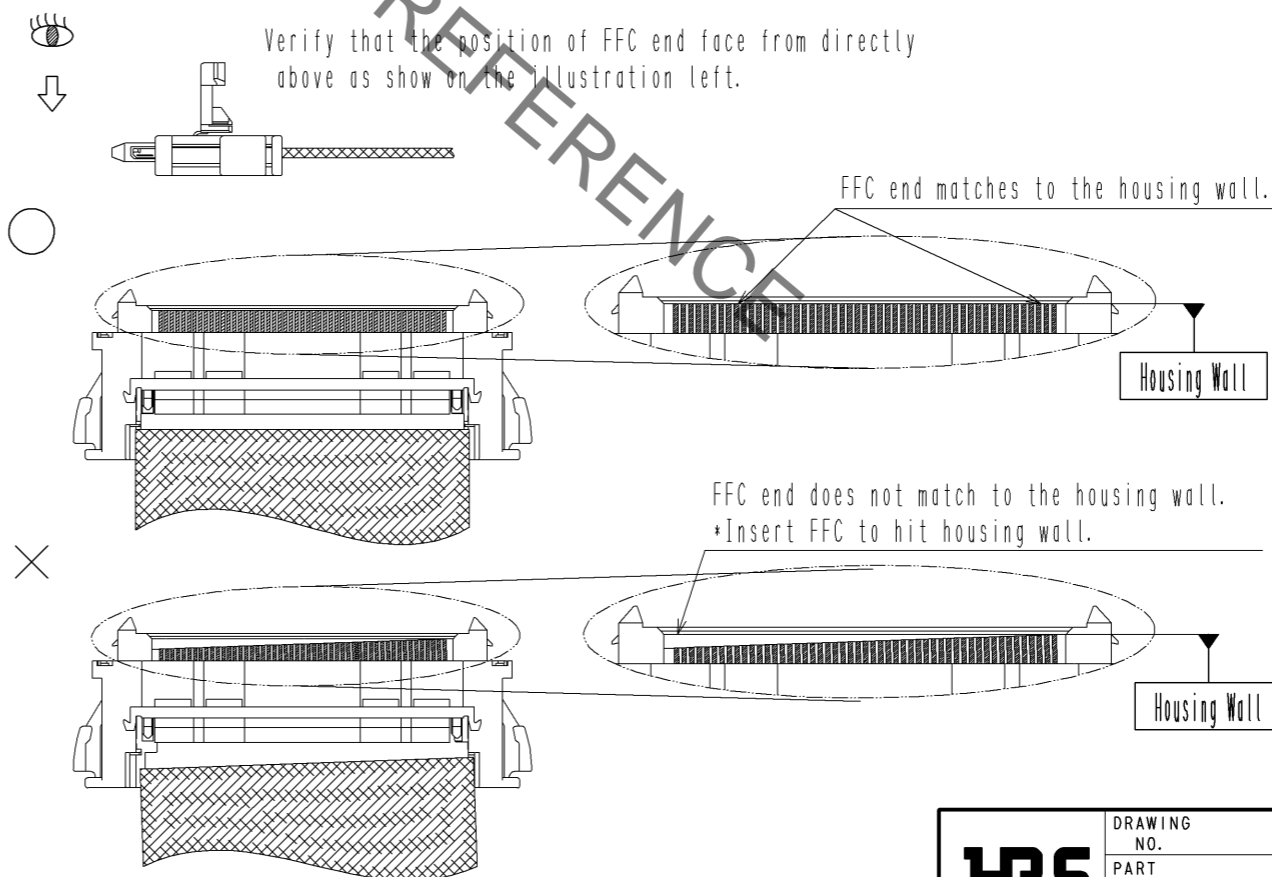

\*NOTE: The figures of the connector shown herein are described with a representative number of contacts just for operation instruction. Therefore, the appearance could differ from the actual connectors. Refer to the drawing for the actual design (sheet 1).

<b>HRS</b>	DRAWING NO.	EDC3-327150-00
	PART NO.	FX16M2-51P-HC
	CODE NO.	CL575-3263-0-00
		3/4/6

HRS DRAWING FOR REFERENCE

Jul.1.2019 Copyright 2019 HIROSE ELECTRIC CO., LTD. All Rights Reserved.  
In case of consideration for using Automotive equipment / device which demand high reliability, kindly contact our sales window correspondents.

Wholly-revised

### [3] How to fix FFC

Hold the connector with both hands and put the thumb near the hook of both sides of the hinged actuator as shown in the figure below.  
Then push down both sides of the hinged actuator at the same time.  
After closing hinged actuator, hold both sides of the plastic housing and pull the FFC to FFC layout direction by 3 to 5N, then verify that FFC does not come off from the plastic housing and fit to both side hooks completely.

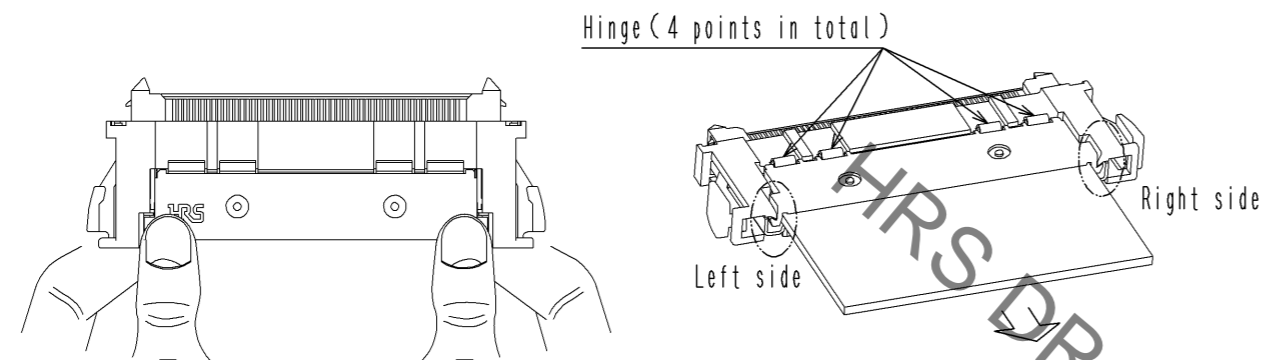

Verify that FFC does not come off when pulling by 3 to 5 N.

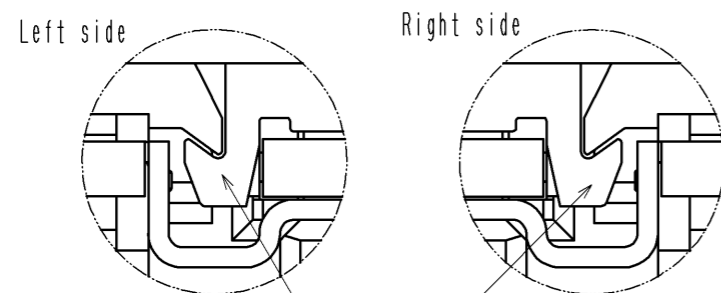

Verify that the fittings at both side hook completely.

Crack or fracture on hinge connection generated after closing hinge actuator is acceptable, provided that it is only 1 of 4 points, which does not influence the connection performance. However, crack or fracture on more than 2 hinge connections affect FFC retention force, therefore avoid using the connector.

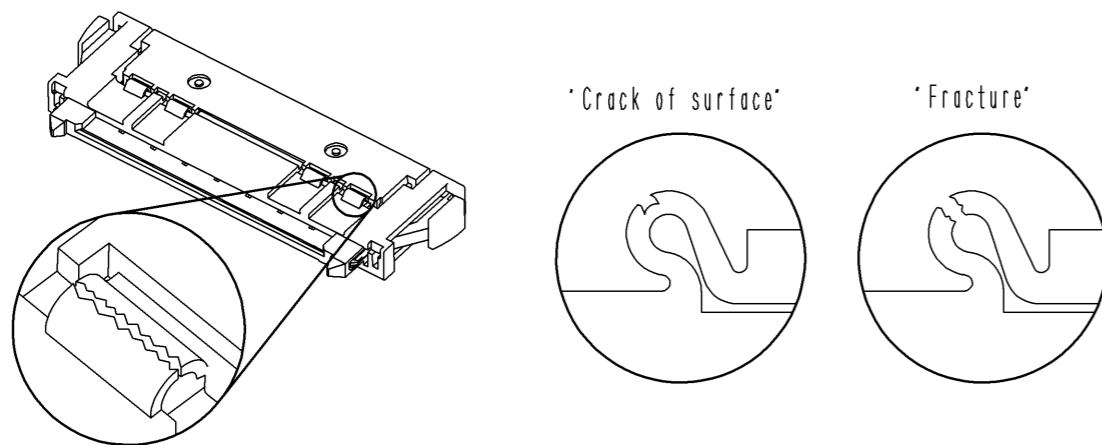

### [4] Other precautions

① Do not apply forces to the hinged actuator to the direction as shown below, and also avoid closing it to the locked position until the correct process in cable assembly. Do not use the connector when this happens.

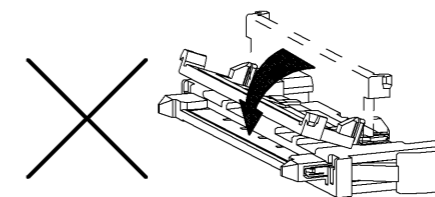

② Once removing the FFC from the plug housing after cable assembly, do not reuse.  
③ For the packing of the plug after cable assembly, do not damage and/or deform the product.

HIROSE DRAWING FOR REFERENCE

\*NOTE: The figures of the connector shown herein are described with a representative number of contacts just for operation instruction. Therefore, the appearance could differ from the actual connectors. Refer to the drawing for the actual design (sheet 1).

<b>HRS</b>	DRAWING NO.	EDC3-327150-00	3/5/6
	PART NO.	FX16M2-51P-HC	
	CODE NO.	CL575-3263-0-00	

Jul.1.2019 Copyright 2019 HIROSE ELECTRIC CO., LTD. All Rights Reserved.  
 In case of consideration for using Automotive equipment / device which demand high reliability, kindly contact our sales window correspondents.

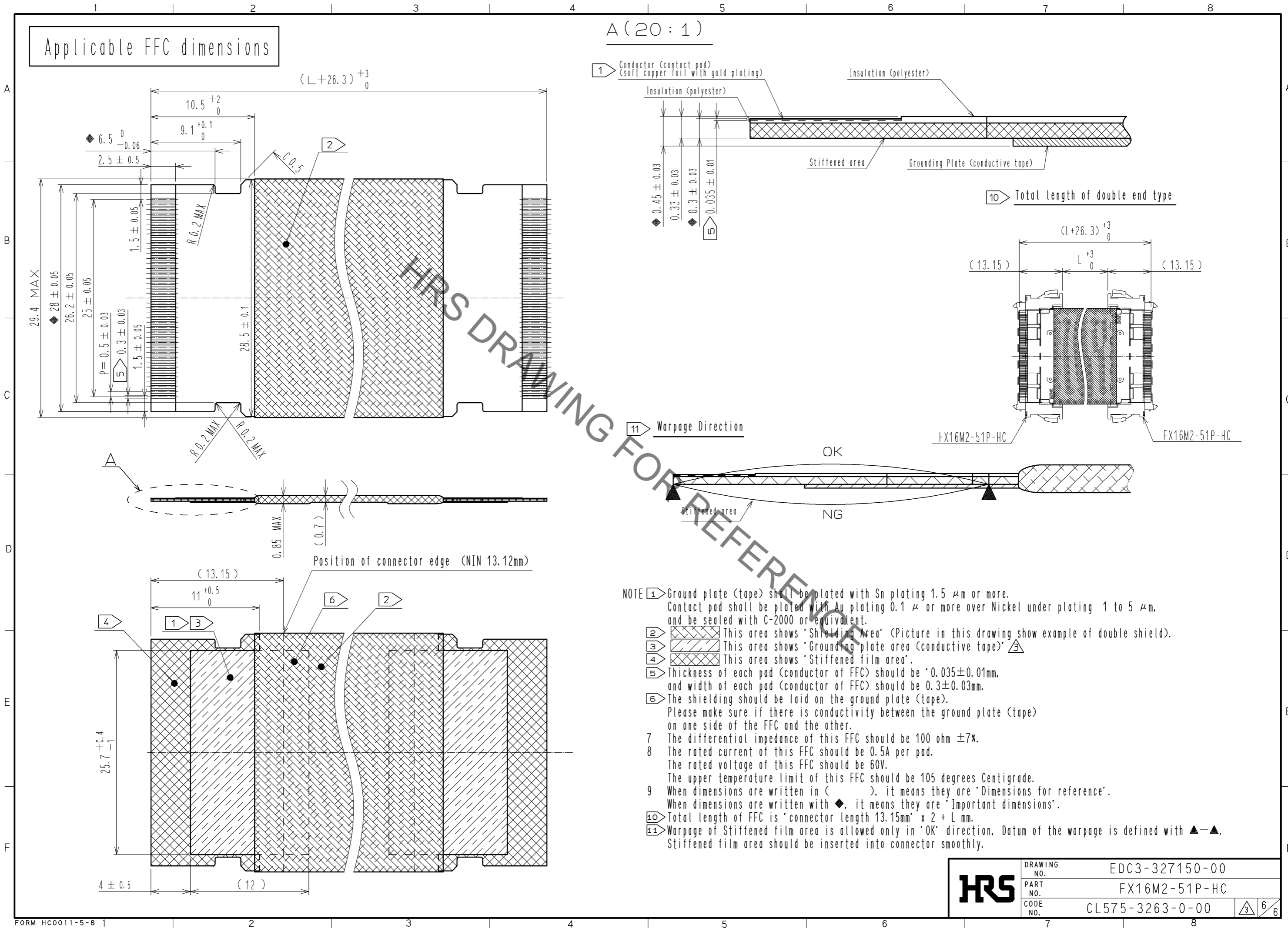

A(20:1)

Applicable FFC dimensions

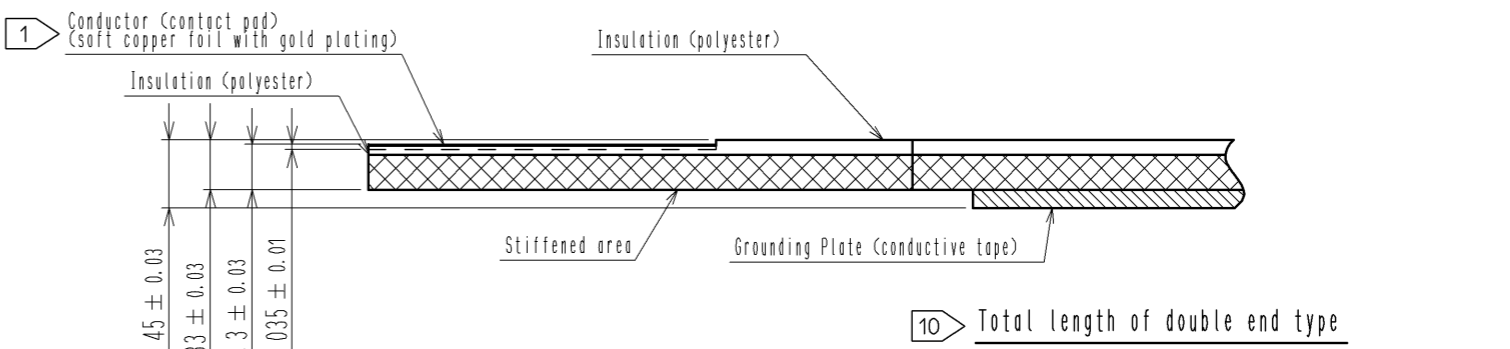

10 Total length of double end type

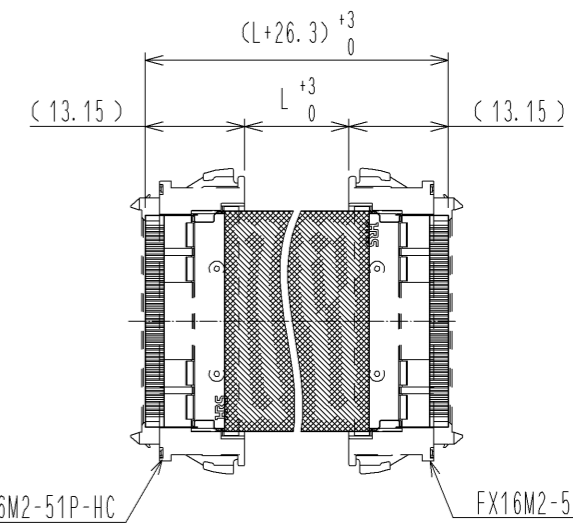

11 Warpage Direction

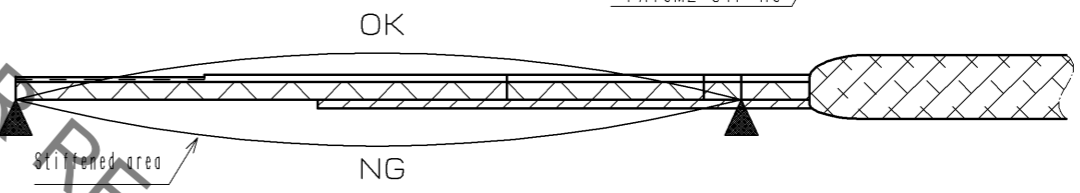

- NOTE
- 1 Ground plate (tape) shall be plated with Sn plating 1.5 μm or more. Contact pad shall be plated with Au plating 0.1 μm or more over Nickel under plating 1 to 5 μm, and be sealed with C-2000 or equivalent.
  - 2 This area shows 'Shielding Area' (Picture in this drawing show example of double shield).
  - 3 This area shows 'Grounding plate area (conductive tape)'.
  - 4 This area shows 'Stiffened film area'.
  - 5 Thickness of each pad (conductor of FFC) should be 0.035±0.01mm, and width of each pad (conductor of FFC) should be 0.3±0.03mm.
  - 6 The shielding should be laid on the ground plate (tape). Please make sure if there is conductivity between the ground plate (tape) on one side of the FFC and the other.
  - 7 The differential impedance of this FFC should be 100 ohm ±7%.
  - 8 The rated current of this FFC should be 0.5A per pad. The rated voltage of this FFC should be 60V. The upper temperature limit of this FFC should be 105 degrees Centigrade.
  - 9 When dimensions are written in ( ), it means they are 'Dimensions for reference'. When dimensions are written with ◆, it means they are 'Important dimensions'.
  - 10 Total length of FFC is 'connector length 13.15mm' x 2 + L mm.
  - 11 Warpage of Stiffened film area is allowed only in 'OK' direction. Datum of the warpage is defined with ▲-▲. Stiffened film area should be inserted into connector smoothly.

<b>HRS</b>	DRAWING NO.	EDC3-327150-00
	PART NO.	FX16M2-51P-HC
	CODE NO.	CL575-3263-0-00

# Mouser Electronics

Authorized Distributor

Click to View Pricing, Inventory, Delivery & Lifecycle Information:

[Hirose Electric:](#)

[FX16M2-51P-HC](#)